

FT-703R

TECHNICAL SUPPLEMENT

This booklet contains supplemental technical information related to the FT-703R for use with the FT-703R Operating Manual. Service or repairs to the FT-703R transceiver should be performed by qualified technicians only.

20FL01

RIARD
10805

YAESU MUSEN CO., LTD.
C.P.O. BOX 1500
TOKYO, JAPAN

CHIP COMPONENT INFORMATION

Transistors

Location	Nomenclature	Mark
Q2010,2013,2015,2020,2021,2022,2023,2025	2SA1162GR	SG
Q1011,2004,2005,2006	2SC2620B	QB
Q1005,1006,1009,1010,2011,2014,2018,2019,2024,2026,2027	2SC2712GR	LG
Q1003	2SC2759	U22
Q2003	2SC3120	HB
Q1001	2SC3356	R22

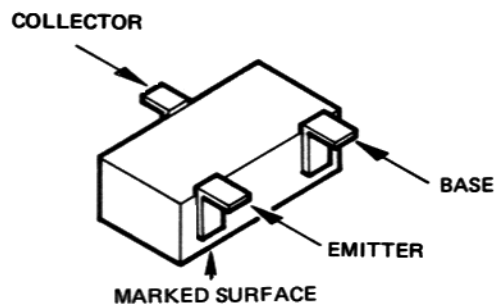
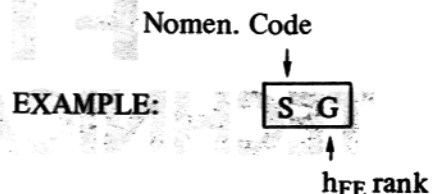

FETs

Q2017	2SK2080	JO
Q2001	2SK210Y	YY
Q2002	2SK242	T3

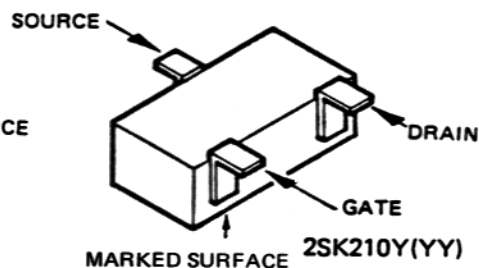
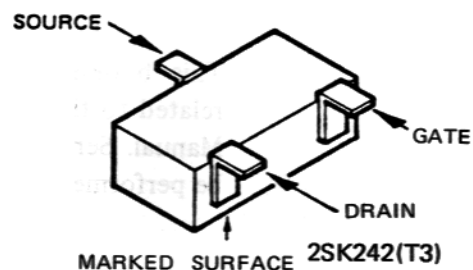
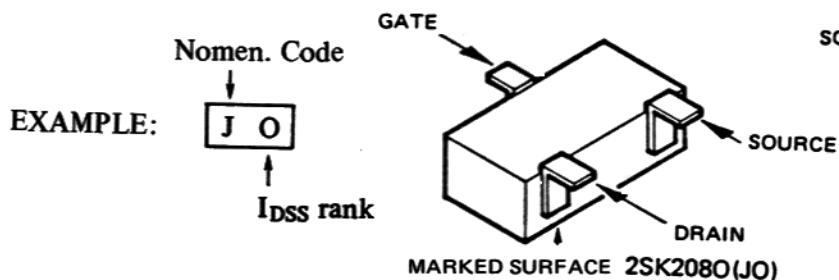

Diodes

D1005,2012,2013,2016	1SS184	B3
D2017	1SS224	C1
D1001	1SS226	C3

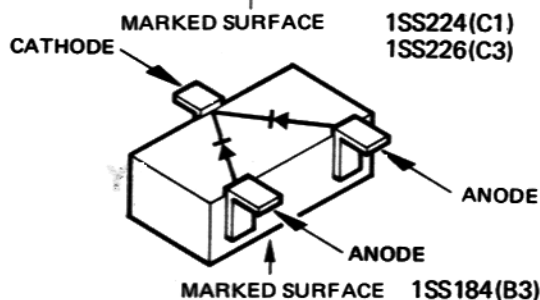
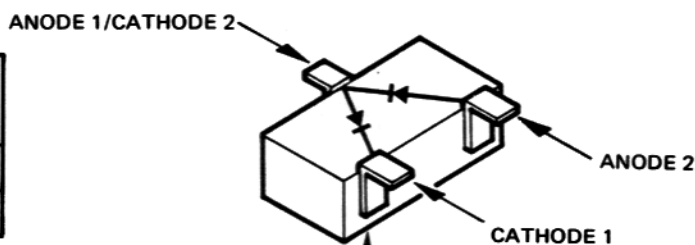
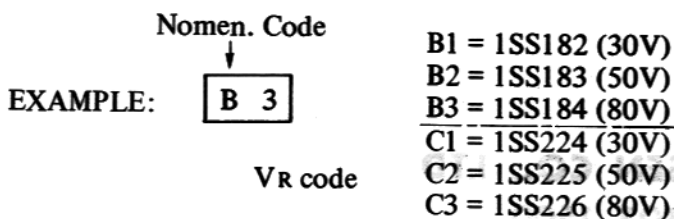

Resistors

Type RMC 1/10W

Marking* A1

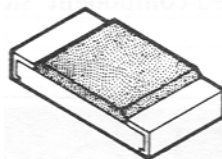

A	1.0	N	3.3
B	1.1	P	3.6
C	1.2	Q	3.9
D	1.3	R	4.3
E	1.5	S	4.7
F	1.6	T	5.1
G	1.8	U	5.6
H	2.0	V	6.2
J	2.2	W	6.8
K	2.4	X	7.5
L	2.7	Y	8.2
M	3.0	Z	9.1

0	1
1	10 ¹
2	10 ²
3	10 ³
4	10 ⁴
5	10 ⁵
6	10 ⁶

Examples:

A1 = 10Ω

J3 = 2.2kΩ

S4 = 47kΩ

Jumper (0Ω) Chip

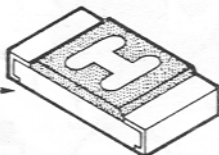

Tantalum Capacitor

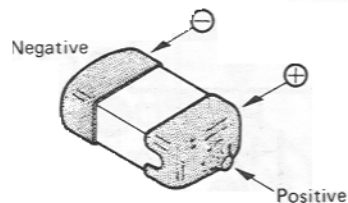

Polarized, Unmarked
(determine value from layout
and Parts List)

Ceramic Capacitors

Types: C2012

C3216

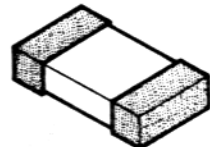

Marking* C3216

C2012

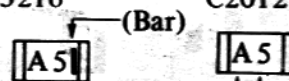

Value code

Multiplier code

A	1.0	M	3.0	Y	8.2
B	1.1	N	3.3	Z	9.1
C	1.2	P	3.6	a	2.5
D	1.3	Q	3.9	b	3.5
E	1.5	R	4.3	d	4.0
F	1.6	S	4.7	e	4.5
G	1.8	T	5.1	f	5.0
H	2.0	U	5.6	m	6.0
J	2.2	V	6.2	n	7.0
K	2.4	W	6.8	t	8.0
L	2.7	X	7.5	y	9.0

0	1
1	10 ¹
2	10 ²
3	10 ³
4	10 ⁴
5	10 ⁵
6	10 ⁶
7	-
8	10 ⁻²
9	10 ⁻¹

C3216 types use a bar marking for either thermal coefficient or tolerance ranking, (according to capacitance value range) as below

Temperature Compensating Types (low values)

No bar = SL-type

NPO(CH)	N150(PH)	N220(RH)	N330(SH)	N470(TH)	N750(UJ)
[] []	[] []	[] []	[] []	[] []	[] []

Dielectric Constant (Hi-K) Types (high values)

B	D
[] []	[] []

No bar = F

Cap. Tolerance

B = 10%

D = 20%

F = +80%/-20%

Examples:

A1 = 10pF NPO

J3I = 0.0022μF D

IA3 = 0.001μF B

CHIP SEMICONDUCTOR CROSS-REFERENCE

PART LOCATION NO.	ORIGINAL	REPLACEMENT		
	NOMENCLATURE (MARKING) AND PART NUMBER	NOMENCLATURE (MARKING) AND PART NUMBER		
Q2010,2013,2015,2020,2023,2025	2SA1162GR(SG) G31111620G	2SA812F/G(M6/M7) G3108120F/G	2SA1052C/D(MC/MD) G3110520C/D	2SA1179F/G(M6/M7) G3111790F/G
Q2006	2SC2620B(QB) G3326200B	2SC2619B(FB) G3326190B		
Q1005,1006,1009,1010,2011,2014,2018,2019,2024,2026,2027	2SC2712GR(LG) G3327120G	2SC1623F/G(L6/L7) G3316230F/G	2SC2462C/D(LC/LD) G3324620C/D	2SC2812F(L6) G3328120F
Q2003	2SC3120(HB) G3331200	2SC2759(U22) G3327590		
Q2017	2SK2080(JO) G38020800	2SK2090(XO) G38020900	2SK303B(V2) G3803030B	2SK3680(KAO) G38036800
D1005,2012,2013,2016	1SS184(B3) G2070009	1S2838(A6) G2070018	DCB015TA(A6) G2070012	
D2017	1SS224(C1) G2070016	1SS123(A7) G2070020	MA153(MC) G2070022	
D1001	1SS226(C3) G2070003	1SS123(A7) G2070020		

* Semiconductors not listed above may be replaced only with original types.

MAIN UNIT PARTS LAYOUT
(obverse view of 'mixed component' side)

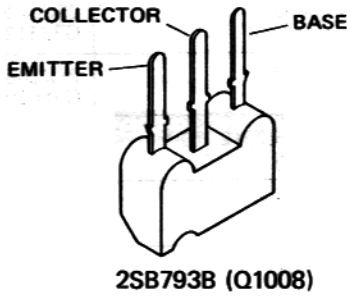
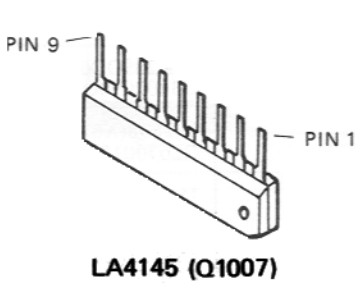
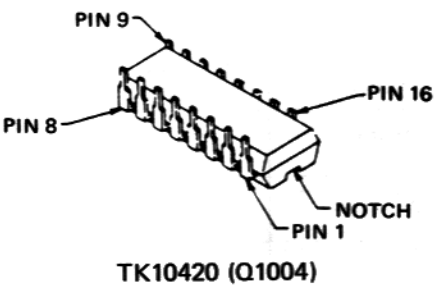
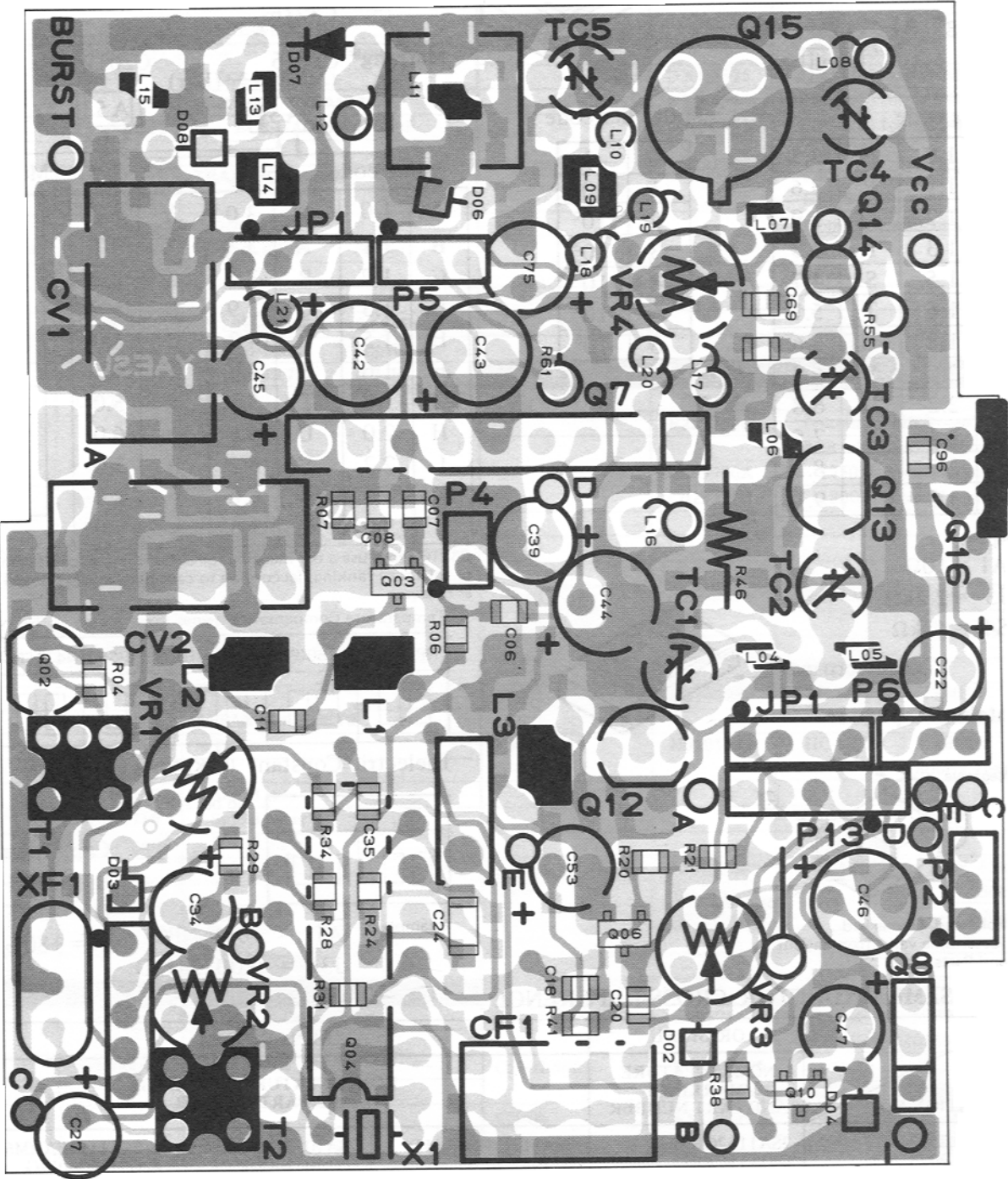

MAIN UNIT PARTS LAYOUT
(reverse view of 'chip-only' side)

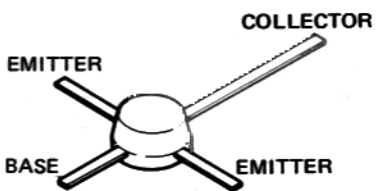
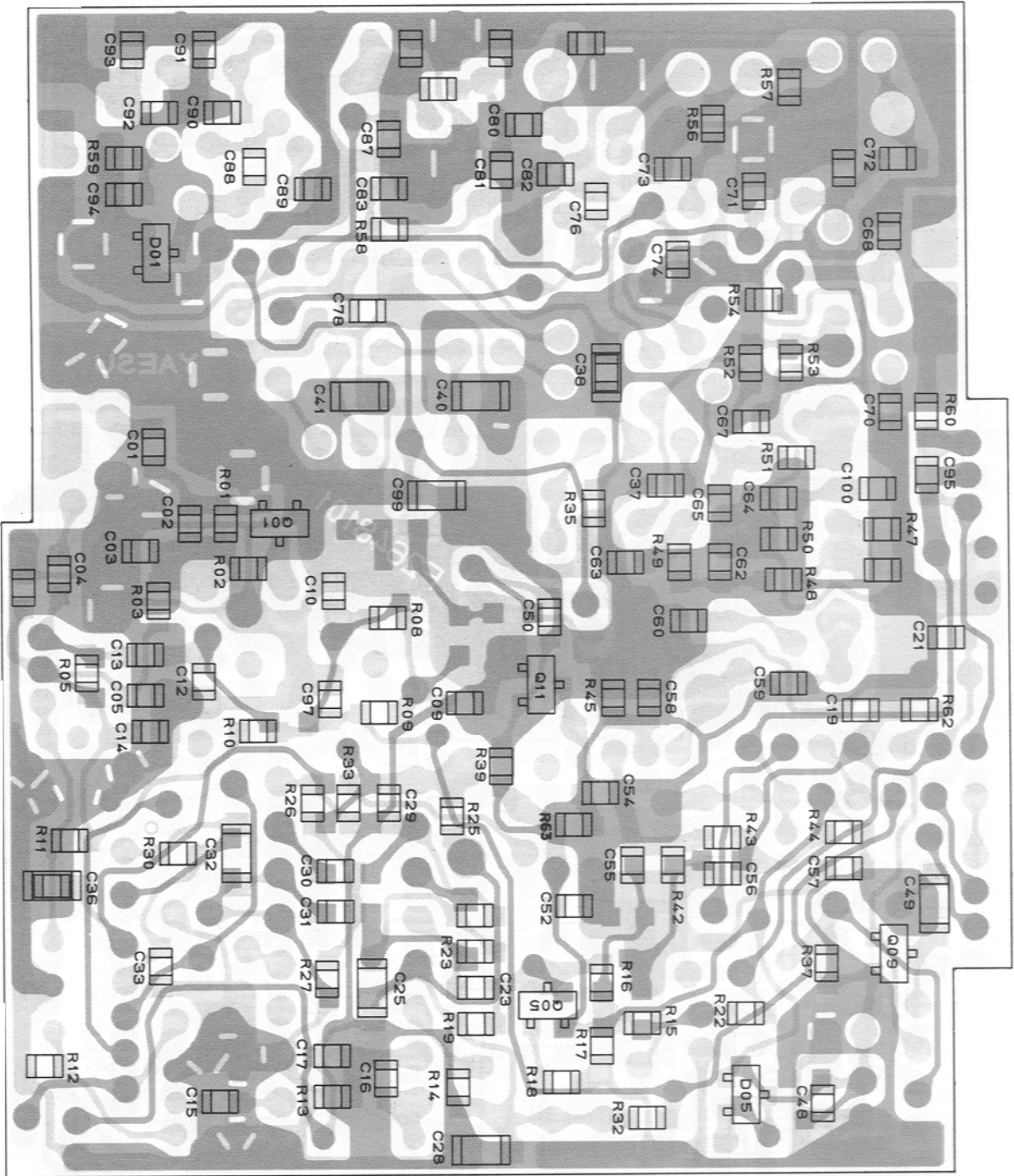

2SC3019 (Q1014)

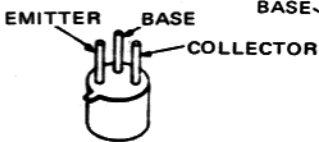

2SC3101 (Q1015)

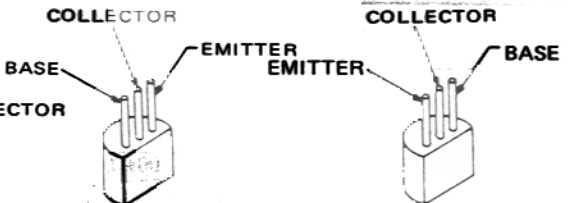

2SC458B (Q1016)

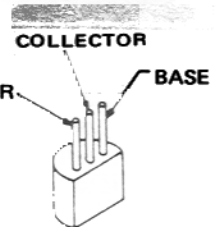

2SC2026 (Q1002,1012)
2SC2407 (Q1013)

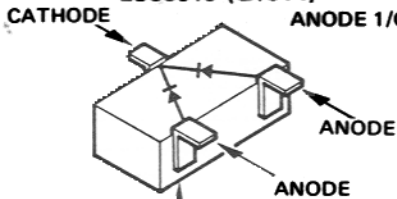

MARKED SURFACE
1SS184 (B3) (D1005)

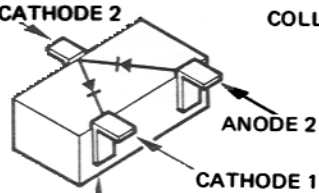

MARKED SURFACE
1SS226 (C3) (D1001)

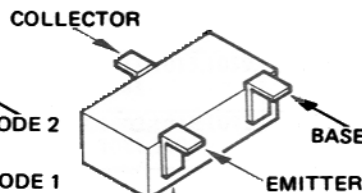

MARKED SURFACE

2SC2620B(QB) (Q1011)
2SC2712GR(LG)
(Q1005,1006,1009,1010)
2SC2759(U22) (Q1003)
2SC3356(R22) (Q1001)

MAIN UNIT PARTS LAYOUT
(obverse view 'chip-only' side)

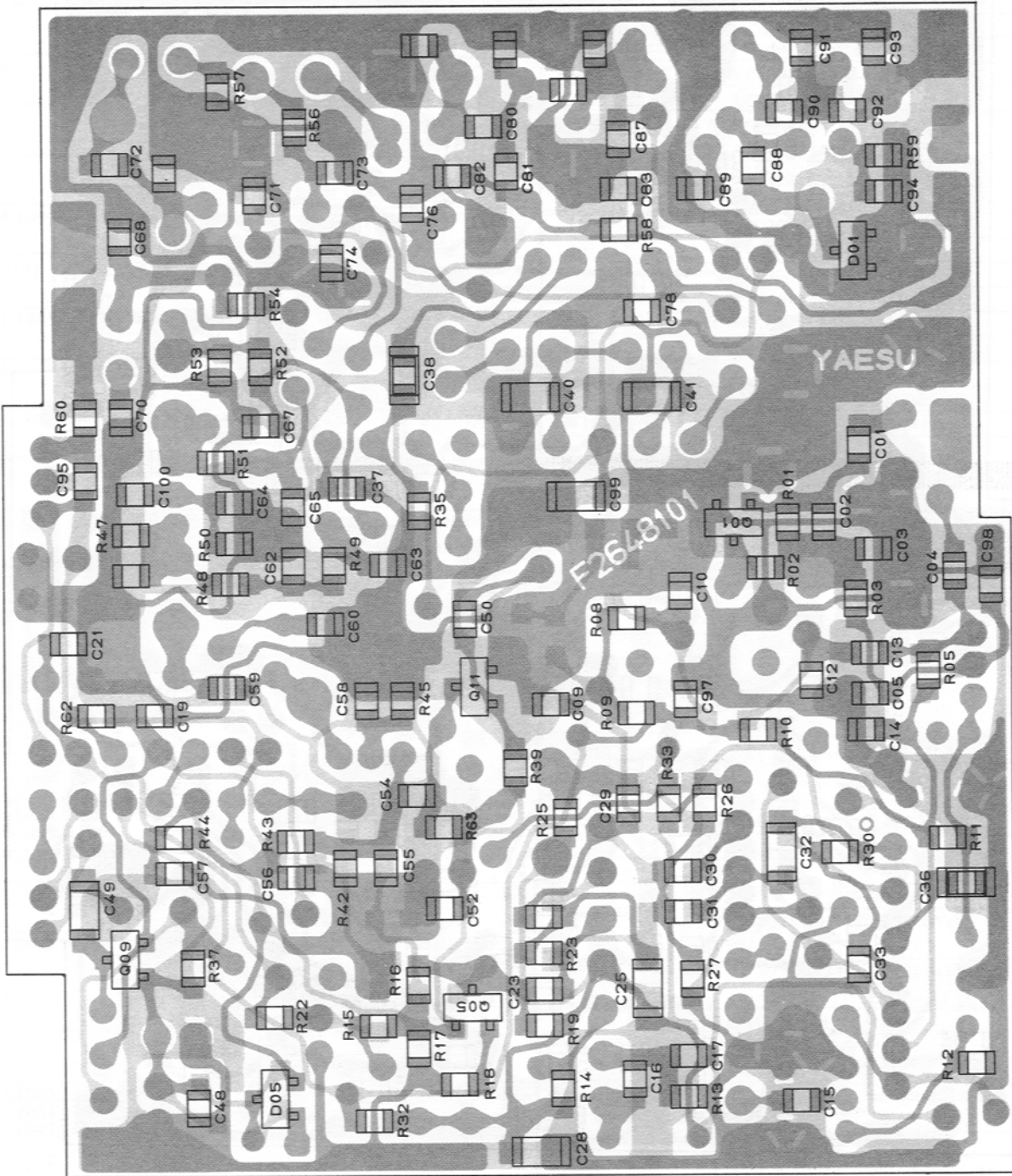

MAIN UNIT PARTS LAYOUT
(reverse view of 'mixed component' side)

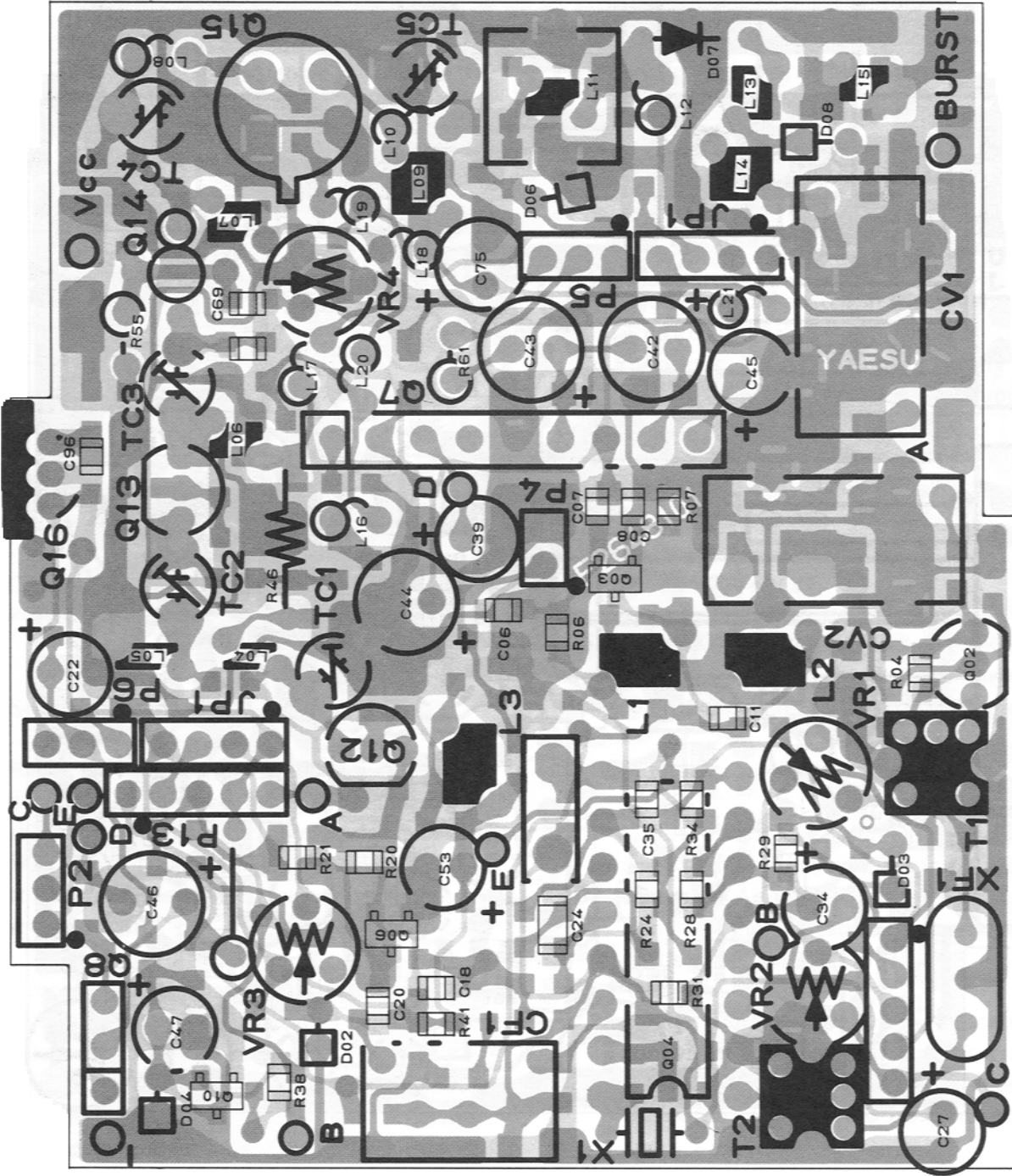

Radio Manuals
www.amateurmanuals.co.uk
 Specialists in Obsolete Manuals

Yaesu, Kenwood, Icom, KW, Henry, Tokyo Hi-Power, ERA, Trio, KDK, FDK, Azden, Standard, AOR, SMC, Sagra, MML, NRD, JRC, Alinco plus many more.
 Amateur and Commercial/Marine

PLL UNIT PARTS LAYOUT
(obverse view of 'mixed component' side)

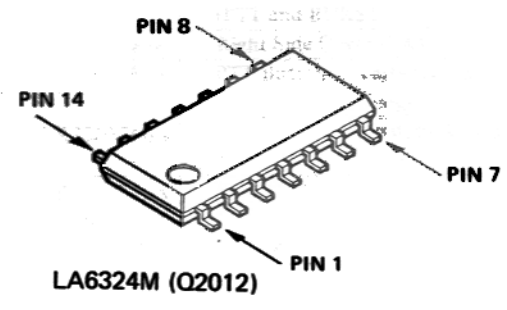
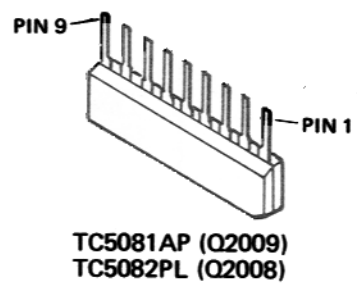
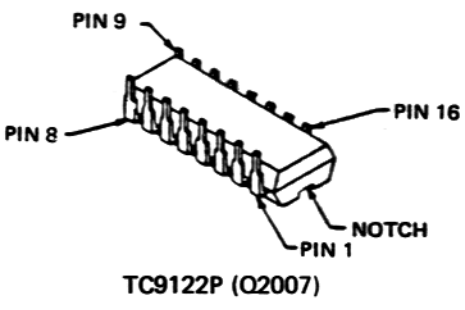
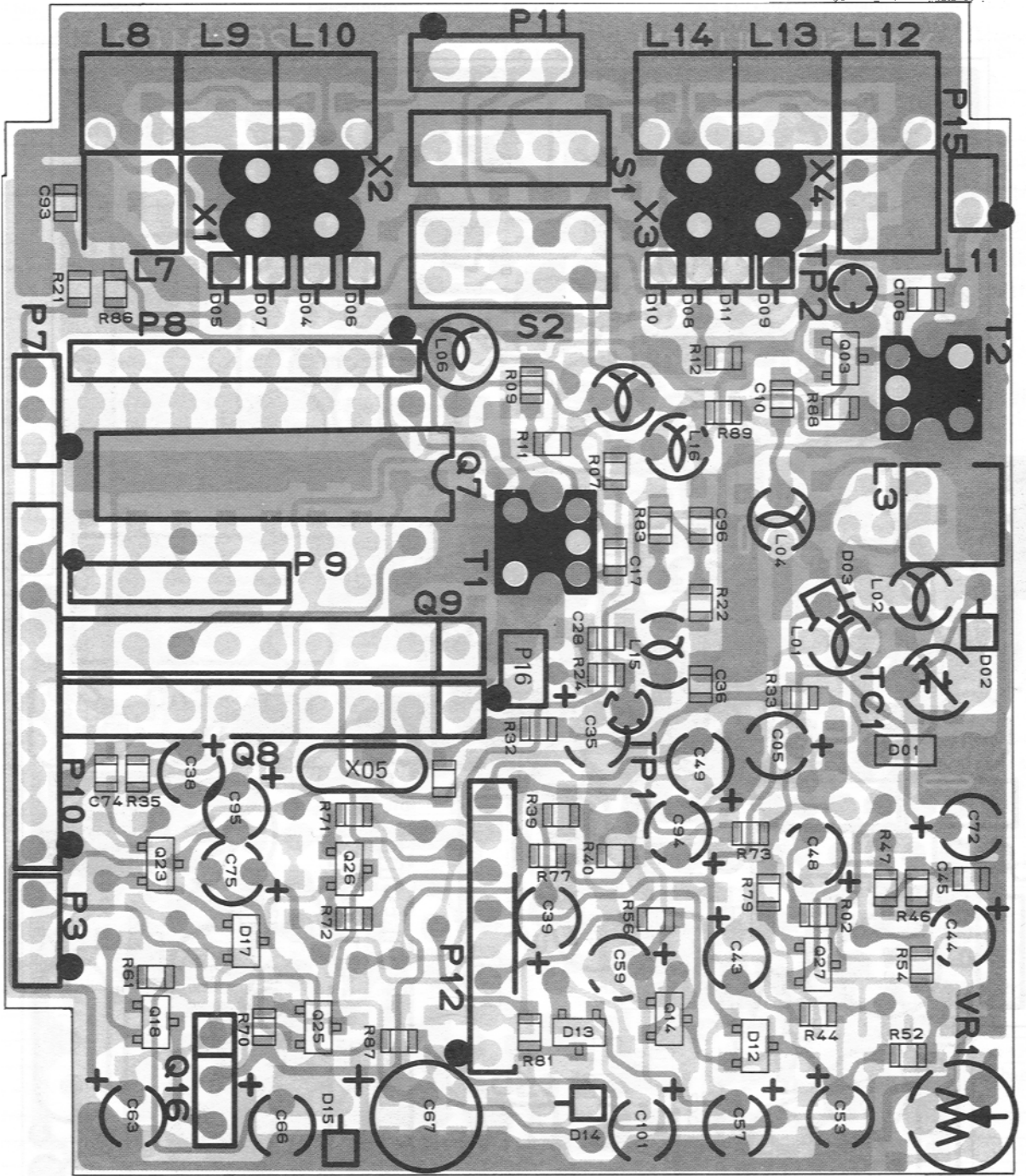

**PLL UNIT PARTS LAYOUT
(reverse view of 'chip-only' side)**

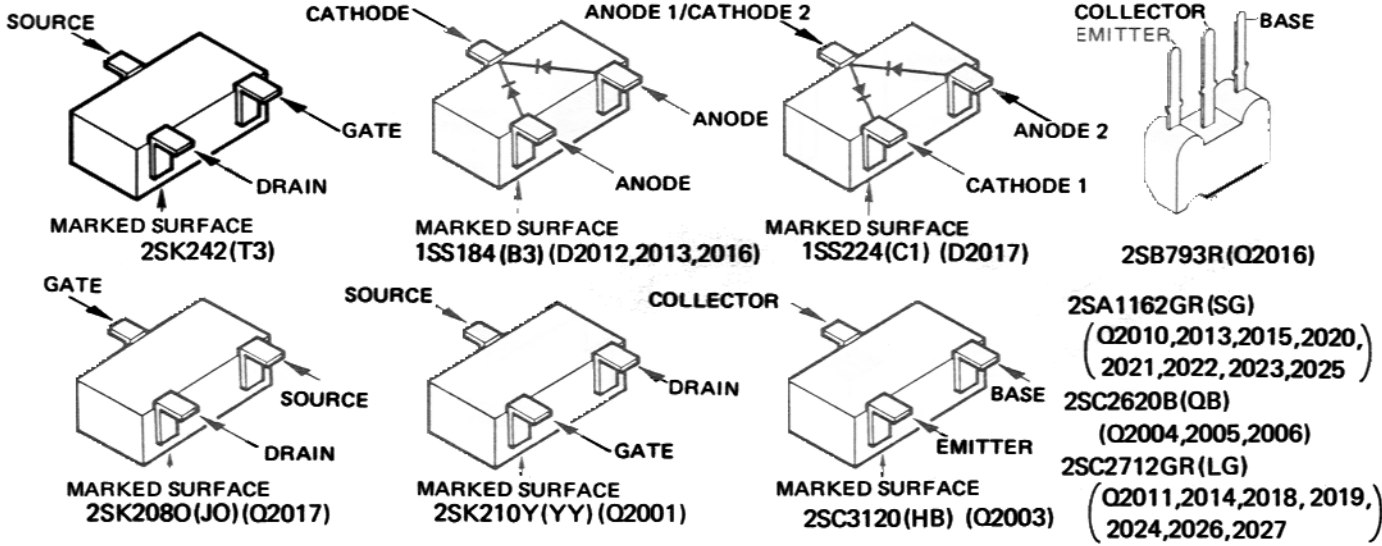
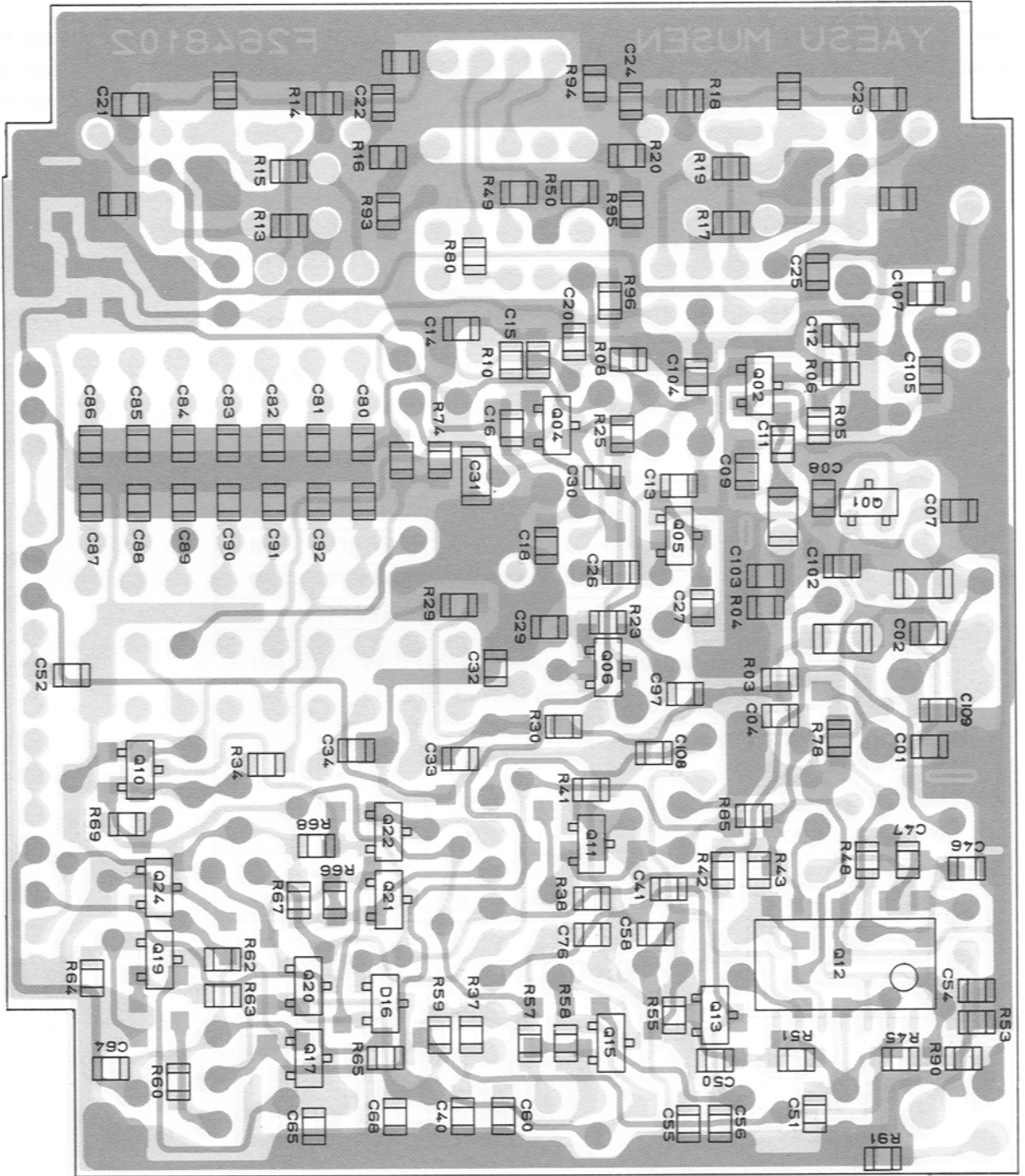

PLL UNIT PARTS LAYOUT
(obverse view of 'chip-only' side)

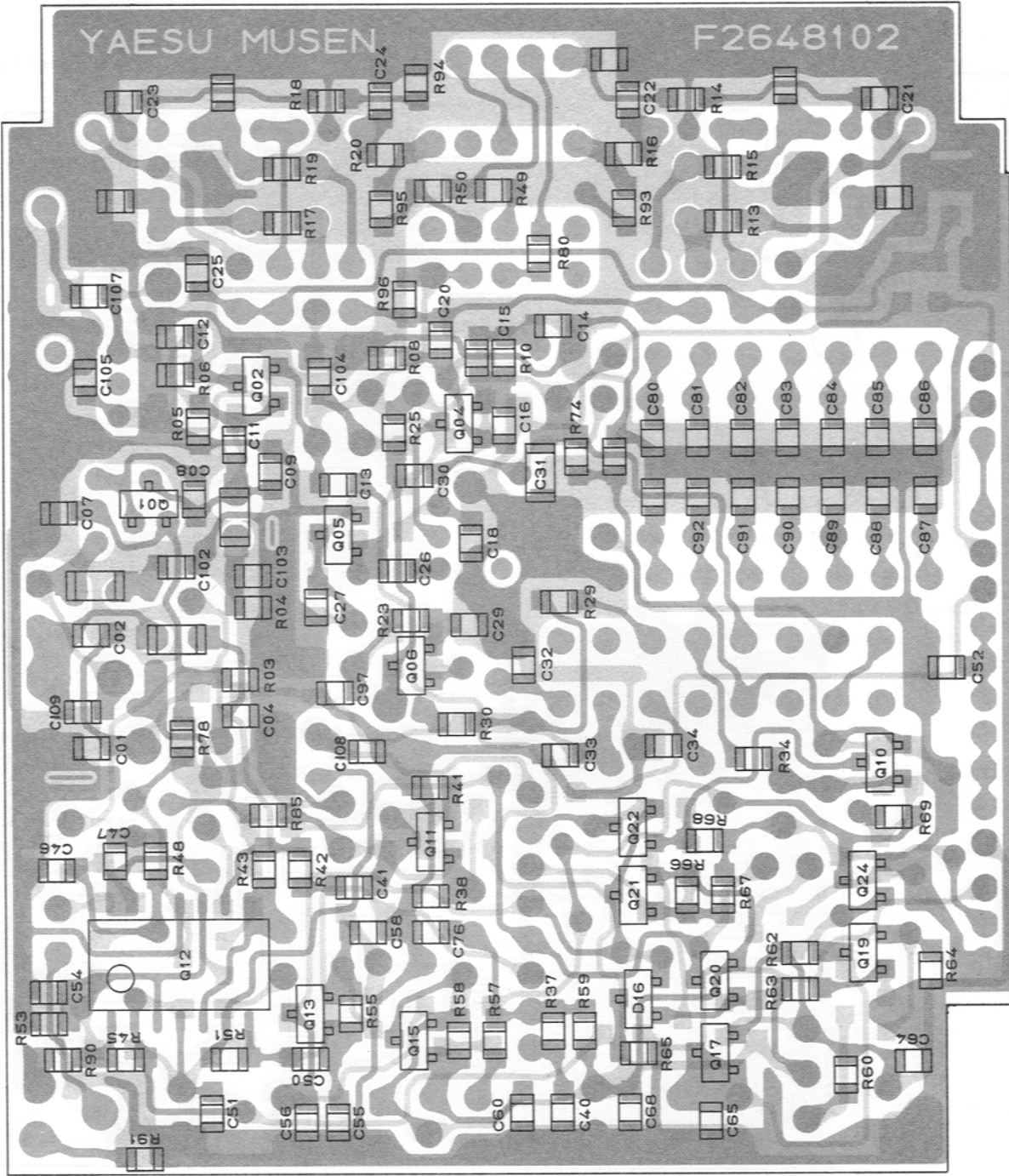

Radio Manuals

www.amateurmanuals.co.uk

Specialists in Obsolete Manuals

Yaesu, Kenwood, Icom, KW, Henry, Tokyo Hi-Power, ERA, Trio, KDK, FDK, Azden, Standard, AOR, SMC, Sagra, MML, NRD, JRC, Alinco plus many more.
Amateur and Commercial/Marine

PLL UNIT PARTS LAYOUT
(reverse view of 'mixed component' side)

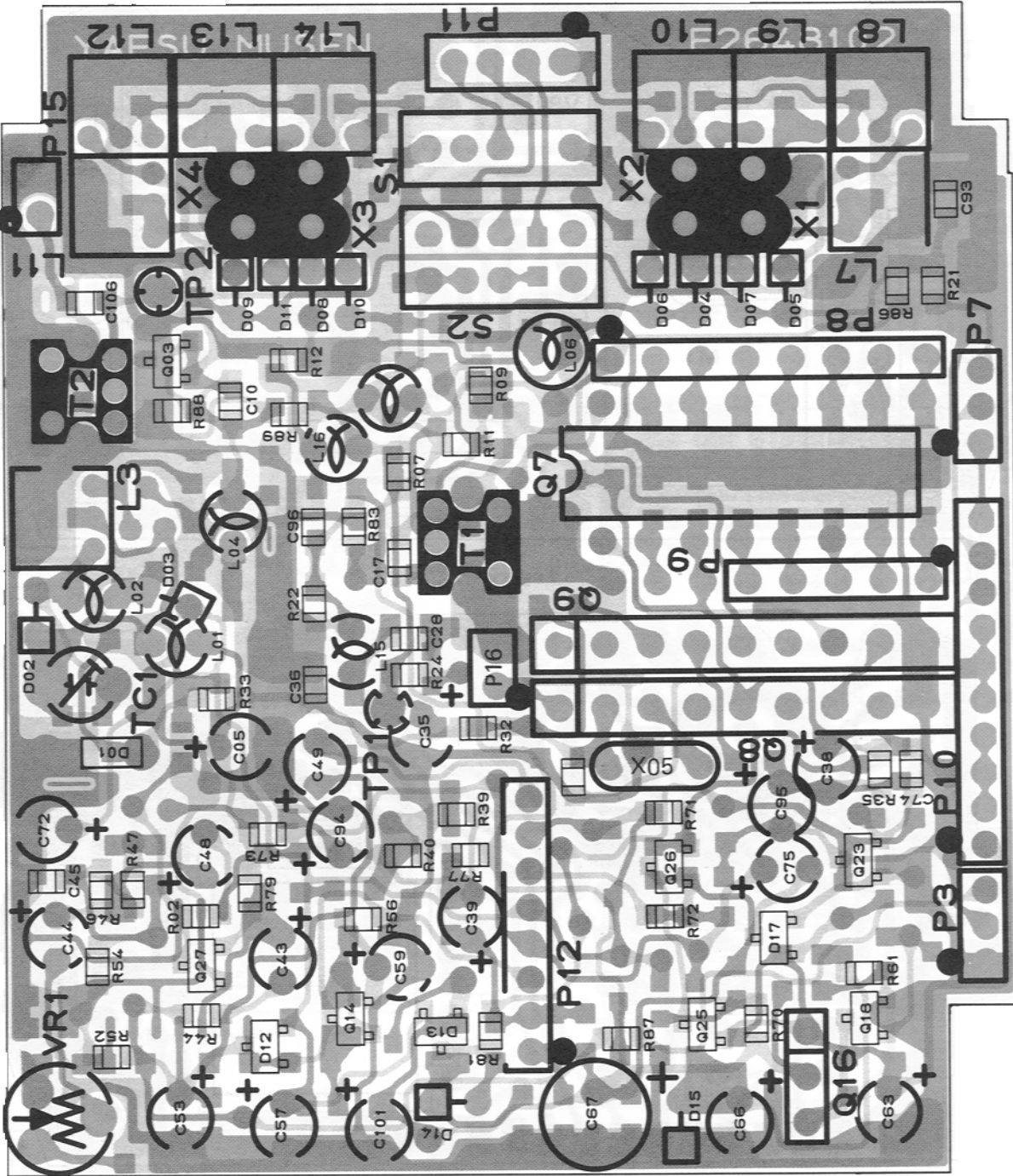

PANEL UNIT ASSEMBLY

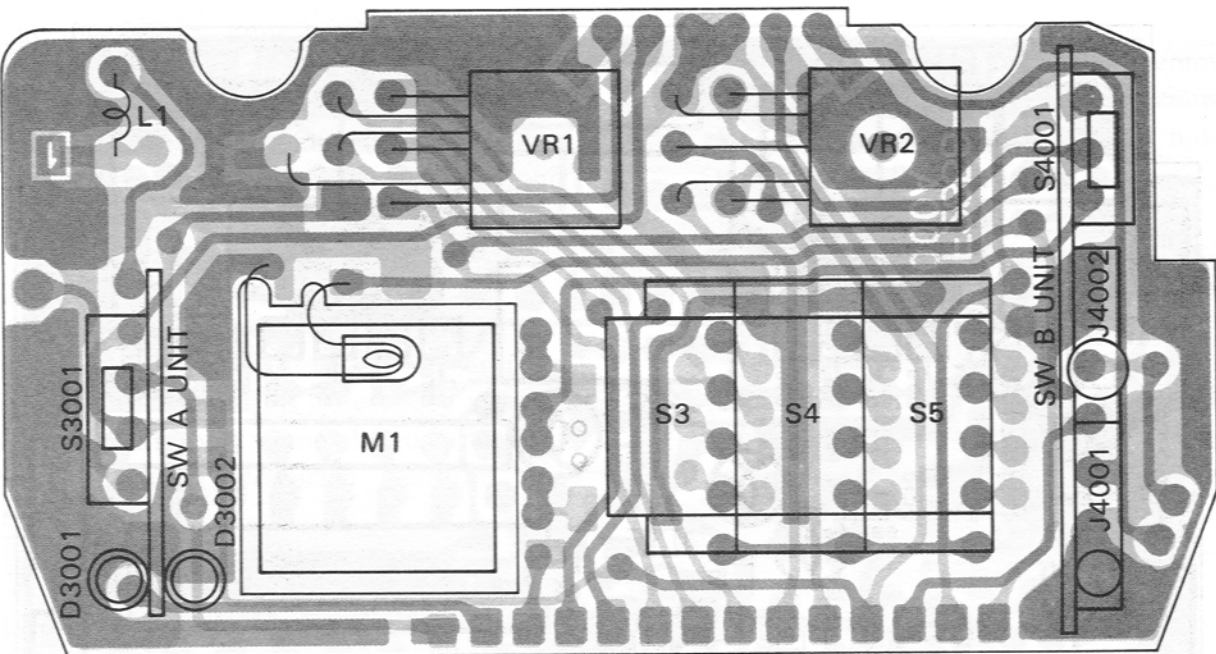

Top view

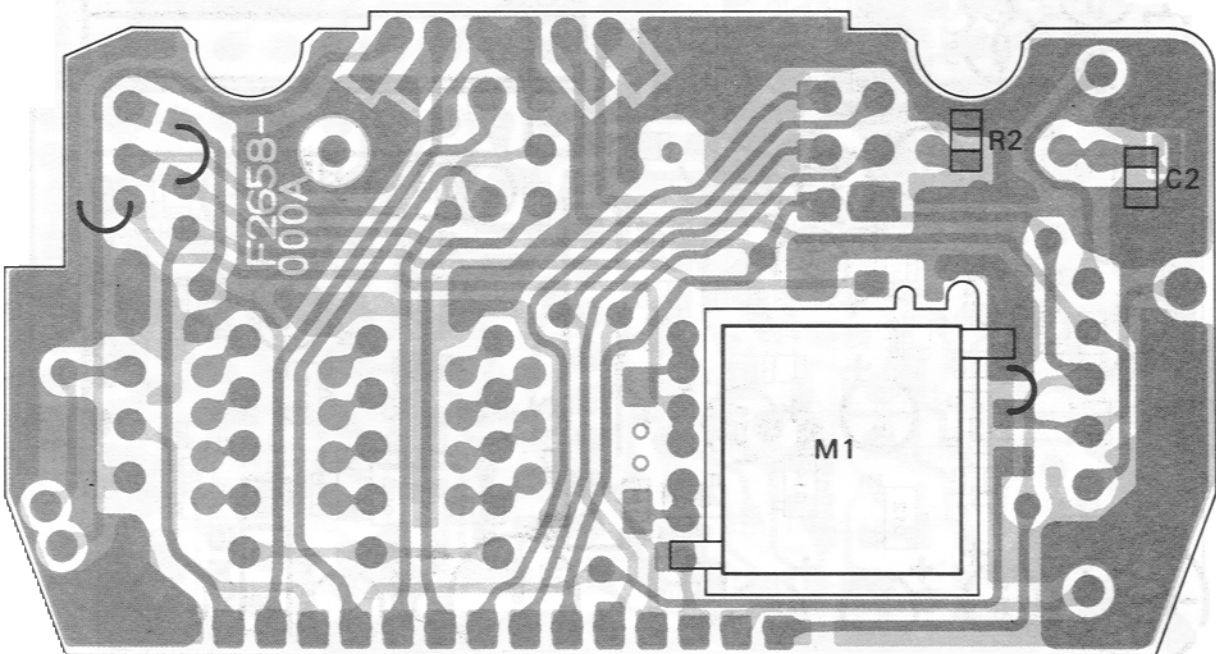

Bottom view

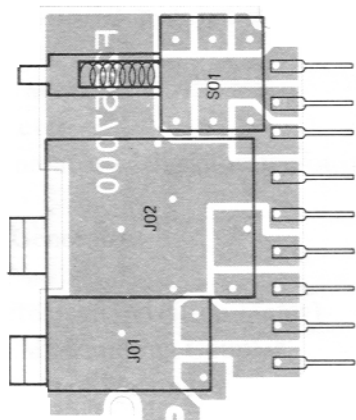

SWITCH B UNIT

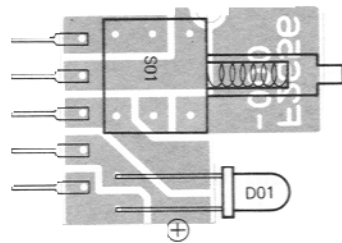

SWITCH A UNIT

MAINTENANCE AND ALIGNMENT

This transceiver has been carefully aligned and tested at the factory prior to shipment. If not abused, it should not require other than the usual attention given to electronic equipment: do not store for long periods of time with the battery installed, protect from high temperature and humidity, avoid dusty or sandy environments, and do not drop the transceiver on a hard surface.

Should service be required, we recommend that the transceiver be returned to the dealer from whom it was purchased. This is necessary to make use of the warranty policy, and also to ensure that a properly qualified technician performs the service.

Replacement of a major component may require considerable realignment. Under no circumstances, though, should realignment be attempted unless the operation of the transceiver circuitry is completely understood. The malfunction should first be carefully analyzed, and any faulty parts replaced before alignment. Service must only be performed by experienced personnel using the proper test equipment.

A 50-ohm dummy load must be connected to this transceiver at all times when the transmitter is activated during alignment. Troubleshooting or alignment using an antenna can result in misleading indications on the test equipment. Also, while this transceiver can operate from a wide range of DC supply voltages, all alignment steps require 10.8 VDC only. Do not use any other voltage for alignment.

Test equipment required:

DC Voltmeter with 10-megohm impedance
DC Milliammeter
RF Voltmeter accurate to 450 MHz
AF Millivoltmeter
RF Signal Generator with calibrated output to 450 MHz
Audio Signal Generator
SINAD Meter
FM Linear Detector (Deviation Meter)
Directional (CM) Sampling Coupler
50-ohm Terminated Wattmeter
Frequency Counter accurate to 450 MHz

Case Removal

1. Referring to the exploded view, remove the battery case or pack, and then remove the four screws affixing the battery mounting track.
2. Remove the two screws affixing the belt clip, and finally the strap mounting screw and the strap mounting dummy screw.
3. Separate the front and rear panels carefully from the chassis, so as not to damage the wiring to the speaker and microphone on the front panel. Note carefully the way in which the PTT and LAMP buttons are hinged.

PLL Circuit

Because of certain thermally sensitive, interacting components in the PLL circuitry, particular attention must be paid to assure a constant ambient temperature at the circuit during alignment. If the transceiver temperature is different than that of the alignment environment, allow sufficient time for thermal equalization before proceeding. Alignment temperature must remain constant and be within the range of 20 to 30°C (68 to 86°F).

Furthermore, proper alignment requires that the shield cover be in place over the VCO, and that the circuit board be mounted in place on the chassis.

A. PLL Local Output Transformer

With the transceiver set to the center of the operating band (435.0 or 445.0 MHz), connect the RF voltmeter to the TP₂₀₀₁ and adjust T₂₀₀₁ for maximum deflection on the voltmeter (at least 350 mVrms).

B. VCV

With the transceiver set to the low edge of the operating band, connect the high impedance DC voltmeter between junction of R₂₀₃₂/R₂₀₃₃/C₂₀₃₆ and chassis ground, and adjust L₂₀₀₃ for 1.5V on receive, adjust TC₂₀₀₁ for 1.5V on transmit on the meter.

C. PLL Local Frequency

1. Set the transceiver to the center of the operating band (435.0 or 445.0 MHz) and connect the frequency counter to the TP₂₀₀₂.
2. With the +5 kHz button in the undepressed position, refer to Table I and adjust L₂₀₀₈, L₂₀₁₂, L₂₀₁₄ and L₂₀₁₀ for the frequencies indicated for the model type being aligned. Set the RPT switch to the appropriate position for each transmit adjustment.

3. Now press the +5 kHz button and referring to Table II, adjust L₂₀₀₇, L₂₀₁₁, L₂₀₁₃ and L₂₀₀₉ for the frequencies indicated for the model type being aligned, as in the previous step.

**TABLE I PLL Local Frequency Adjustment
(+5 kHz button not depressed)**

	Receive (L2008)	SIMPLEX (L2012)	RPT (+) (L2014)	RPT (-) (L2010)
A	141.13333	148.33333	150.00000	146.66667
B	137.80000	145.00000	—	142.46667
C	137.80000	145.00000	145.53333	—
X	137.80000	145.00000	146.66667	143.33333

**TABLE II PLL Local Frequency Adjustment
(+5 kHz button depressed)**

	Receive (L2007)	SIMP (L2011)	RPT (+) (L2013)	RPT (-) (L2009)
A	141.13500	148.33500	150.00167	146.66833
B	137.80167	145.00167	—	142.46833
C	137.80167	145.00167	145.53500	—
X	137.80167	145.00167	146.66833	143.33500

OVERALL EXPLODED VIEW

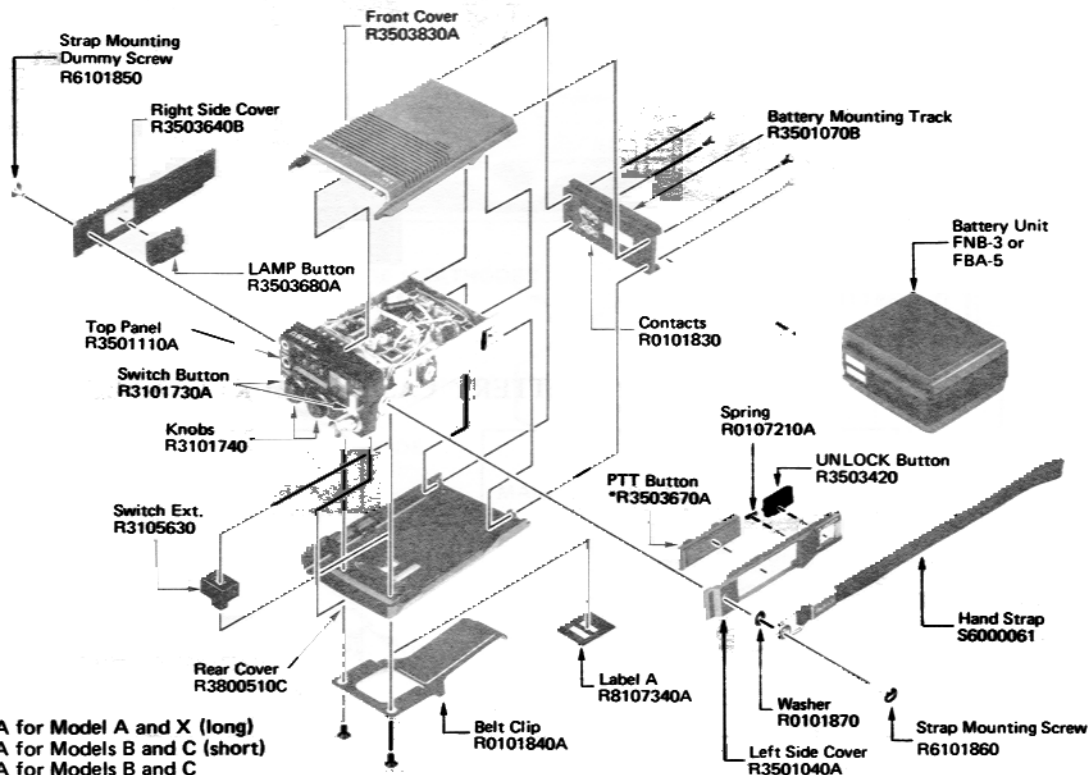

*PTT R3503670A for Model A and X (long)
R3503660A for Models B and C (short)
BURST R3503650A for Models B and C

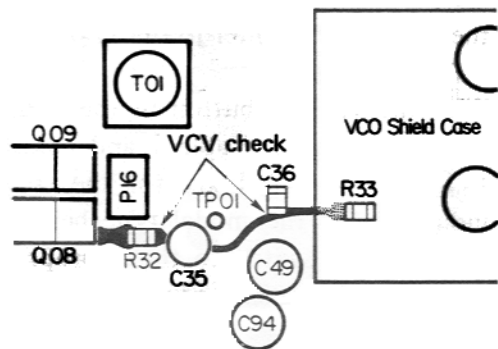
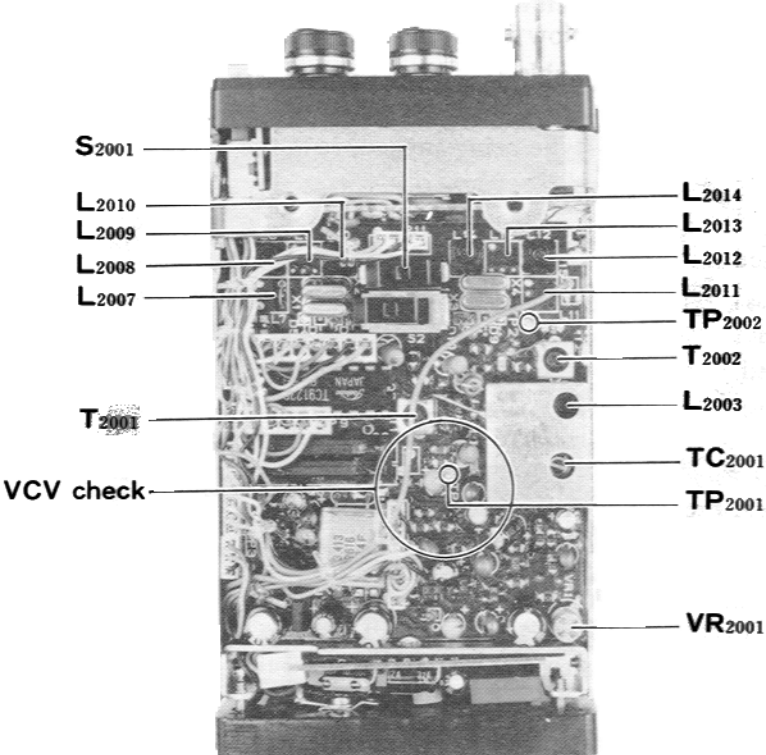

PLL UNIT alignment points

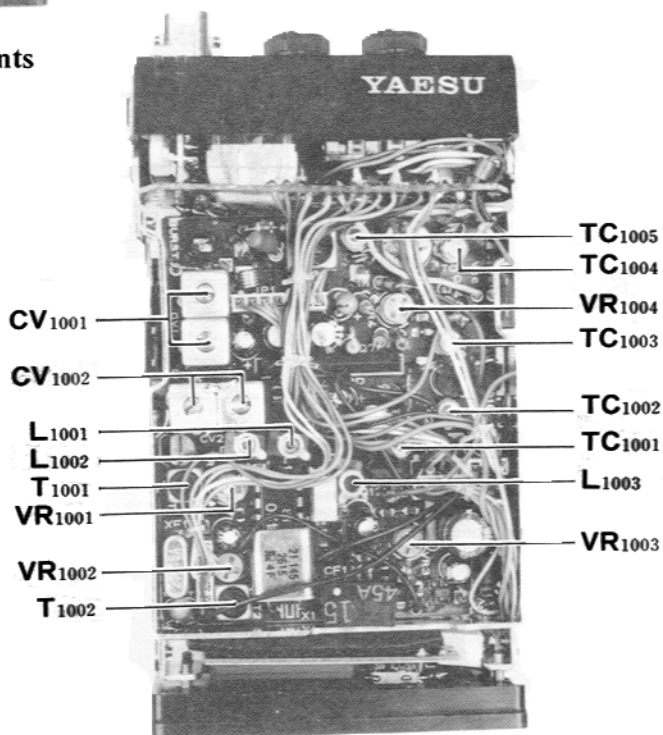

MAIN UNIT alignment points

POWER SUPPLY (BATTERY CASE or PACK) CONNECTIONS

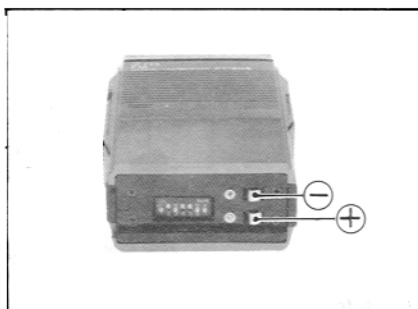
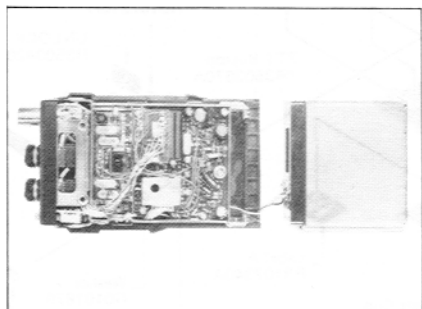

A. Signal Path

1. Connect the test equipment as shown in the following diagram, and tune the transceiver and generator to 435.00 or 445.00 MHz. Modulate the signal generator with 1 kHz of audio with ± 3.5 kHz FM deviation, and set the generator output level to $0.25 \mu\text{V}$ ($-6 \text{ dB}\mu$).
2. Adjust CV_{1001} , CV_{1002} , L_{1001} , L_{1002} , T_{1001} and T_{1002} to obtain optimum SINAD, which should be 12 dB or better.

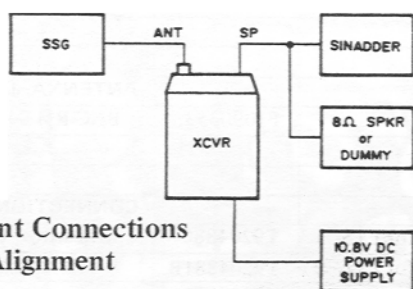

Test Equipment Connections
for Receiver Alignment

B. Squelch Circuit

1. With the transceiver tuned to 435.00 or 445.00 MHz, replace the signal generator with the dummy load at the antenna jack. Set the SQL control to midrange, and adjust VR_{1001} to the point where receiver noise is just squelched off.
2. Reconnect the signal generator to the antenna jack, and set the SQL control fully counter-clockwise into the click-stop (TONE) position. With the same signal generator modulation as in step 1 of the previous procedure, set the generator output level to $8 \text{ dB}\mu$ and adjust VR_{1002} to the squelch threshold point.

Do not transmit without a 50-ohm dummy load connected to the antenna terminal.

A. Signal Path

1. With the terminated wattmeter connected to the antenna jack and the transceiver set to 435.00 or 445.00 MHz, adjust T_{1001} , T_{1002} and L_{1003} for maximum RF output power.
2. With the LOW switch in the out (high power) position, adjust TC_{1003} through TC_{1005} for maximum RF output power during transmission (2.5W nominal @ 10.8 VDC supply).
3. With the LOW switch in the in (low power) position, adjust the VR_{1004} for 300 mW power output (10.8 VDC supply).

B. PO Meter Setting

With the LOW switch in the out (high power) position, adjust VR_{1003} so that the meter on the transceiver deflects to "8" on the numbered scale.

C. Modulator

1. Connect the test equipment as shown below, and set the audio generator for 25 mV output at 1 kHz. Adjust VR_{2001} for ± 4.5 kHz deviation on the deviation meter while transmitting.
2. Reduce the output level of the audio generator while observing the deviation meter, to obtain ± 3.5 kHz deviation. The audio generator output level should now be between 2.5 and 3.5 mV.

Test Equipment Connections for Modulator Alignment

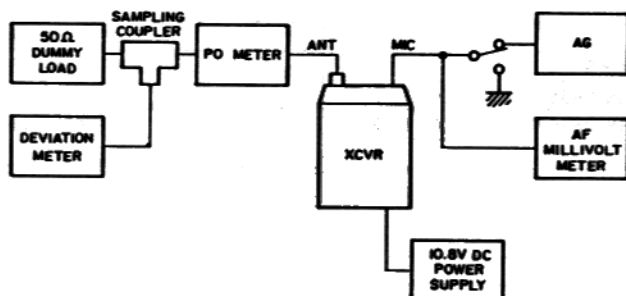

PARTSLIST

MAIN CHASSIS					CAPACITORS
Symbol No.	Part No.	Description	C1,7	K12171102	Ceramic 50WV 0.001 μ F E (DD104E102P50V)
*** PANEL BOARD ASSY ***					
	F2658000	Printed Circuit Board PCB with components w/SW (A), (B) UNIT	C3-6	K22170805	Chip " 0.001 μ F B (C2012B1H102MFA)
MICROPHONE					
S2,3,4	N7090029	THUMBWHEEL SWITCHES A7MA-146-P2 (Frequency select)	MIC1	M3290005	EM-78C
SPEAKER					
			SP1	M4090063	C035A13
POTENTIOMETER					
VR1	J60800104	K09111002-5R1112-5KB 5k Ω B (SQL)			
VR2	J60800105	K0911100B-5R1111-20KA 20k Ω A (VOL)	S1	-	SWITCHES with VR2 (POWER)
			S5,6,7	N4090040	KHG10901 (PTT, LAMP, BURST)
			S8	-	with VR1 (TSQL)
RESISTORS					
R1	J24205222	Chip RMC 1/10T 222J 2.2k Ω			
METER					
M1	M0290044	MH-42F			
CONNECTION PLUG					
			P1,2,3 (for FTS-7)	T9204880	with wire Versions A, X & F
			P1,2,3 (for FTE-2)	T9204881B	" Versions B & C
PL1	Q1000054	#7656 6V 35mA	P4	T9204871	"
			P5	T9204872	"
			P6	T9204873	"
			P7	T9204874	"
			P8	T9204875D	"
			P9	T9204876B	"
			P10-13	T9204879B	"
*** SWITCH UNIT A ***					
	F2656000	Printed Circuit Board			
	C026560A	PCB with Components			
LEDS					
D3001	G2090278	LN38GCP	R3501110A Control Panel w/r and g filters (A, X, B & C)		
	G2090279	LN28RCP			
SWITCH					
S3001	N4090088	SPJ622N09 (HI/LOW)	R3501120A "		
			R3501070B Battery Mounting Track w/ contacts (R0101830)		
			R3503830A Front Cover w/trim band, w/o spkr, mic		
*** SWITCH UNIT B ***					
	F2657000	Printed Circuit Board	R0101820B (Trim band)		
	C026570A	PCB with Components	R3800510F Rear Cover w/o switch label, belt clip		
			R8107340A Switch Label (RPT and VOX)		
			R3107390 Spacer		
S4001	N4090088	SPJ622N09 (CALL or 5 UP)	R3501040A Left Side Cover (PTT) or (PTT and BURST)		
			R3503640B Right Side Cover (LAMP)		
			R3503670A PTT Button Versions B & C (long)		
J4001	P1090369	HSJ0838-01-010 (EXT MIC)	R3503660A " " Versions A, X & F (short)		
J4002	P1090370	HSJ0836-01-010 (EXT EAR)			
			R3503650A BURST Button "		
			R3503680A LAMP Button		
			R3503420 UNLOCK Latch Button		

- Version A
- ▲ Versions B & C
- × Version X
- △ Version F

Symbol No.	Part No.	Description	Part No.	Part No.	Part No.
	R01017210	Spring			
	R0101840B	Belt clip	XF1001	H1102088	CRYSTAL FILTER SET
	S6000061	Hand strap			21P15A
	Q9000284	Insulator			(2pcs: MATCHED PAIR)
	R7103610A	" sheet			
	R3101740	Knob 11TS (VOL and SQL)			CERAMIC FILTER
	R3101730A	Push Button (LOW, and +5kHz or CALL)	CF1001	H3900360	LF-K15X
	R3105630	Switch Extender (RPT and VOX)			
	R6101860	Strap Mounting Screw	CD1001	H7900180	CERAMIC DISCRIMINATOR
	R0101870	Washer			CDB455C7
	R6101850	Strap Mounting Dummy Screw	R1061	J02245229	RESISTORS
	R0801610C	Frame F	R1047,1065	J01215101	Carbon film 1/4W 2.2Ω SJ
	R0503400A	Frame R	R1055	J10246229	" 1/8W 100Ω TJ
	R0503260C	Panel Frame			composition
	R7102620	Fiber Board	R1018	J24205100	2.2Ω GK
			R1050	J24205150	Chip RMC 1/10T 100J 10Ω
			R1057	J24205330	" " " 150J 15Ω
			R1054	J24205470	" " " 330J 33Ω
			R1049	J24205560	" " " 470J 47Ω
			R1045	J24205820	" " " 560J 56Ω
MAIN UNIT			R1007,1010,1041,1053	J24205101	" " " 820J 82Ω
	F2648101A	Printed Circuit Board	R1003,1032,1048,1056	J24205221	" " " 101J 100Ω
	C026480A	PCB with components	R1059	J24205331	" " " 221J 220Ω
		Version A	R1002,1015,1058	J24205471	" " " 331J 330Ω
	C026481A	" " "	R1068	J24205561	" " " 471J 470Ω
		Versions B,C,X & F	R1052,1062	J24205681	" " " 561J 560Ω
			R1009	J24205821	" " " 681J 680Ω
		ICs	R1008,1011,1023,1029,1044,1063,1067(B,C,X,F)	J24205102	" " " 821J 820Ω
Q1004	G1090617	TK10420	R1025	J24205152	" " " 102J 1kΩ
Q1007	G1090558	LA4145	R1042	J24205182	" " " 152J 1.5kΩ
			R1014,1022,1064	J24205222	" " " 182J 1.8kΩ
		TRANSISTORS	R1019	J24205272	" " " 222J 2.2kΩ
Q1008	G3207930R	2SB793R	R1004,1021	J24205332	" " " 272J 2.7kΩ
Q1016	G3304580B	2SC458B	R1027	J24205392	" " " 332J 3.3kΩ
Q1002,1012	G3320260	2SC2026	R1030,1043	J24205472	" " " 392J 3.9kΩ
Q1013	G3324070	2SC2407	R1017,1060	J24205562	" " " 472J 4.7kΩ
Q1011	G3326200B	2SC2620B(QB)	R1012,1026	J24205682	" " " 562J 5.6kΩ
Q1005,1006,1009,1010	G3327120G	2SC2712GR(LG)	R1005,1033	J24205103	" " " 682J 6.8kΩ
Q1003	G3327590	2SC2759(U22)	R1013,1016,1037	J24205223	" " " 103J 10kΩ
Q1014	G3330190	2SC3019	R1034	J24205273	" " " 223J 22kΩ
Q1015	G3331010	2SC3101	R1001,1035	J24205333	" " " 273J 27kΩ
Q1001	G3333560	2SC3356(T2B)	R1024,1038,1039,	J24205473	" " " 333J 33kΩ
			R1031	J24205104	" " " 473J 47kΩ
			R1006	J24205154	" " " 104J 100kΩ
		DIODES	R1028	J24205474	" " " 154J 150kΩ
D1003,1010	G2015550	Si 1S1555	R1020	J24205564	" " " 474J 470kΩ
D1005	G2070009	" 1SS184(B3)			" " " 564J 560kΩ
D1001	G2070003	" 1SS226(C3)			POTENTIOMETERS
D1007,1008,1009	G2090277	" 1SS205	VR1004	J51762221	H0521A103A-220B 220ΩB
D1002,1006	G2090244	Schottky 1SS106	VR1003	J51762103	H0521A113A-10KB 10kΩB
D1004	G2090227	Zener HZ9B2L	VR1001,1002	J51762104	H0521A119A-100KB 100kΩB
		CRYSTAL			CAPACITORS
X1001	H0102608	HC-49/T 22.055MHz	C1104,1109	K12171102	Ceramic 50WV 0.001μF E
		Version A	C1011,1013,1059,1081	K22170201	(DD104E102P50)
X1001	H0102615	" 21.145MHz	C1002,1012,1072,1082,1092	K22170204	Chip 50WV 0.5pF CH
		Versions B,C,X & F			(C2012CH1H0R5CFA)
					" " 3pF "
					(C2012CH1H030CFA)

C1092	K22170205	Chip 50WV 4pF (C2012CH1H040CFA)	CH	TC1003,1004 TC1005	K91000101 K91000100	ECR-GA010D30 10pF ECR-GA020E30 20pF
C1010,1050,1088	K22170206	Chip 50WV 5pF (C2012CH1H050CFA)	..			TRANSFORMERS
C1107	K22170207	Chip 50WV 6pF (C2012CH1H060DFA)	..			
C1093	K22170208	" " 7pF (C2012CH1H070DFA)	..	L1001,1002 L1003	L0190022 L0190122	
C1080	K22170209	" " 8pF (C2012CH1H080DFA)	..	L1004,1005 L1006,1007,1011, 1013,1015	L0020425 L0020875A	
C1089	K22170210	" " 9pF (C2012CH1H090DFA)	..	L1008,1010	L0020876	
C1006,1091	K22170211	" " 10pF (C2012CH1H100DFA)	..	L1009 L1014	L0020423 L0020342	
C1007(A)	K22170213	" " 12pF (C2012CH1H120JFA)	..	L1016-1022 L1012	L1020677 L1190108	FL3H-R68M 0.68μH
C1001,1055	K22170215	" " 15pF (C2012CH1H150JFA)	..		L9190039	Coil case KS7-5
C1090	K22170223	" " 33pF (C2012CH1H330JFA)	..			CAVITIES
C1003,1016,1094	K22170227	" " 47pF (C2012CH1H470JFA)	..	CV1001,1002	Q9000114	CV-441B
C1029	K22170233	" " 82pF (C2012CH1H820JFA)	..			
C1017	K22170237	" " 120pF (C2012CH1H121JFA)	..			
C1023	K22170239	" " 150pF (C2012CH1H151JFA)	..			
C1030	K22170243	" " 220pF (C2012CH1H221JFA)	..			
C1004,1005,1008, 1009,1019,1021, 1031,1037,1048, 1052,1054, 1056-1058, 1062-1065, 1067-1069,1071, 1073,1074,1076, 1078,1083,1087, 1095-1098,1100, 1101-1103,1108	K22170805	" " 0.001μF B (C2012B1H102MFA)	B			ICs
				Q2007	G1090247	TC9122P
				Q2008	G1090560	TC5082PL
				Q2009	G1090473	TC5081AP
				Q2012	G1090559	LA6324M
C1035	K22170817	" " 0.01μF B (C2012B1H103MFA)	B			FETs
C1014,1015,1018, 1033	K22171004	" " 0.01μF F (C2012F1H103ZFA)	F	Q2001	G3802100Y	2SK210Y(Y)
C1038	K22140807	" " 0.022μF B (C2012B1E223MFA)	B	Q2017	G38020800	2SK208-O(JO)
C1020	K22171008	" " 0.047μF F (C2012F1H473ZFA)	F	Q2002	G3802420C	2SK242(T3)
C1024,1025,1028, 1032,1036,1040, 1041,1049,1099	K22141904	" " 0.1μF D (C3216D1E104MFA)	D			TRANSISTORS
C1027,1075	K70120002	Tantalum 16WV 10μF (489D106X0016C1)		Q2010,2013,2015, 2020-2023,2025	G3111620G	2SA1162GR(SG)
C1047	K40179001	Electrolytic 50WV 1μF (ECE-A1HK010)		Q2016	G3207930R	2SB793R
C1034,1039	K40149011	" 25WV 4.7μF (ECE-A1EK4R7)		Q2004-2006	G3326200B	2SC2620B(QB)
C1022,1045,1053	K40129012	" 16WV 10μF (ECE-A1CK100)		Q2011,2014,2018, 2019,2024,2026, 2027	G3327120G	2SC2712GR(LG)
C1042-1044	K40109015	" 10WV 100μF (ECE-A1AK101)		Q2003	G3331200	2SC3120(HB)
C1046	K40129012	" 16WV 100μF (16RE100)				DIODES
				D2012,2013,2016	G2070009	Si 1SS184(B3)
				D2002-2010, 2011(A,C,X),2014	G2090277	" 1SS205
				D2017	G2070016	1SS224(C1)
				D2001	G2090107	Varactor 1T25
				D2015	G2090176	Zener HZ6A1L
TC1001,1002	K91000105	ECR-GA006A30 6pF				

		CRYSTALS		C2011	K22170202	Chip 50WV 1pF (C2012CH1H010CFA)	CH
X2001(A)	H0102621	UM-1	136.133MHz				
X2001(B,C,X,F)	H0102617	"	132.800MHz	C2008	K22170303	" " 2pF (C2012UJ1H020CFA)	UJ
X2002(A)	H0102620	"	141.666MHz				
X2002(B)	H0102624	"	137.468MHz	C2009	K22170304	" " 3pF (C2012UJ1H030CFA)	"
X2002(X,F)	H0102618	"	138.333MHz				
X2003(A)	H0102622	"	143.333MHz	C2013	K22170206	" 5pF (C2012CH1H050CFA)	CH
X2003(B,C,X,F)	H0102672	"	140.000MHz				
X2004(A)	H0102623	"	145.000MHz	C2001	K22170309	" " 8pF (C2012UJ1H080DFA)	UJ
X2004(C)	H0102625	"	140.535MHz				
X2004(X,F)	H0102620	"	141.666MHz	C2026	K22170211	" " 10pF (C2012CH1H100DFA)	CH
X2005	H0102616A	RW-18T	3.4133MHz				
RESISTORS							
R2087	J24205000	Chip RMC 1/10T	000J 0Ω	C2017,2016(A)	K22170213	" " 12pF (C2012CH1H120JFA)	"
R2083	J24205390	" " "	390J 39Ω	C2032,2109	K22170215	" " 15pF (C2012CH1H150JFA)	"
R2089	J24205560	" " "	560J 56Ω				
R2007,2011,2073, 2074,2077,2085,	J24205101	" " "	101J 100Ω	C2106(B,C,X,F)	K22170217	" 18pF (C2012CH1H180JFA)	"
R2099 (B,C,X,F)	J24205151	" " "	151J 150Ω	C2023(A)2024(A)	K22170321	" " 27pF (C2012UJ1H270JFA)	UJ
R2003,2004,2006, 2010(A),2091	J24205221	" " "	221J 220Ω				
R2041,2011(B,C,X,F)	J24205331	" " "	331J 330Ω	C2033,2034, 2023(C)	K22170223	" " 33pF (C2012CH1H330JFA)	CH
R2010	J24205391	" " "	391J 390Ω	C2021,2022	K22170225	" " 39pF (C2012CH1H390JFA)	"
R2023,2030 2080	J24205471	" " "	471J 470Ω				
R2029,2062,2067, 2078	J24205102	" " "	102J 1kΩ	C2014,2016, 2023(B,C,X), 2033(A,B,X), 2021(B,C,X), 2024(C,X)	K22170325	" " 39pF (C2012UJ1H390JFA)	UJ
R2049,2059,2072	J24205152	" " "	152J 1.5kΩ				
R2014,2016,2018, 2020,2025,2037	J24205222	" " "	222J 2.2kΩ	C2027,2097	K22170229	" " 56pF (C2012CH1H560JFA)	CH
R2050	J24205272	" " "	272J 2.7kΩ				
R2060	J24205332	" " "	332J 3.3kΩ	C2002	K22170239	" " 150pF (C2012CH1H151JFA)	"
R2013,2015,2017, 2019,2057	J24205472	" " "	472J 4.7kΩ	C2007,2028,2041	K22170801	" " 470pF (C2012B1H471MFA)	B
R2064,2090	J24205562	" " "	562J 5.6kΩ				
R2012	J24205682	" " "	682J 6.8kΩ	C2004,2012,2020, 2025,2040,2046, 2051,2052, 2054,2060,2064, 2065,2068,2074, 2076,2080-2093, 2102-2105,2108, 2110,2112,2113, 2115,2118-2122	K22170805	" " 0.001μF (C2012B1H102MFA)	B
R2021	J24205822	" " "	822J 8.2kΩ				
R2022,2040,2055, 2058,2061,2063, 2066,2068,2070, 2071,2081	J24205103	" " "	103J 10kΩ				
R2044,2093-2095	J24205153	" " "	153J 15kΩ	C2045	K22170806	" " 0.0012μF (C2012B1H122MFA)	B
R2008,2047,2048	J24205183	" " "	183J 18kΩ				
R2002,2038, 2046, 2065	J24205223	" " "	223J 22kΩ	C2055,2056	K22170809	" " 0.0022μF (C2012B1H222MFA)	B
R2042	J24205333	" " "	333J 33kΩ				
R2009,2034,2035, 2039,2056,2079, 2086	J24205473	" " "	473J 47kΩ	C2047	K22170813	" " 0.0047μF (C2012B1H472MFA)	B
R2053	J24205683	" " "	683J 68kΩ	C2015,2018,2030, 2036,2050,2096	K22170817	" " 0.01μF (C2012B1H103MFA)	B
R2005,2024,2032, 2033,2051,2069, 2088,2098	J24205104	" " "	104J 100kΩ	C2029,2058	K22171008	" " 0.047μF (C2012F1H473ZFA)	F
R2043,2052	J24205124	" " "	124J 120kΩ	C2031	K22141904	" 25WV 0.1μF (C3216D1E104MFA)	D
R2097	J24205334	" " "	334J 330kΩ	C2039,2043,2044, 2049	K70167104	Tantalum 35WV 0.1μF (CS15E1V0R1M)	
	J24205105	" " "	105J 1MΩ	C2075	K70140007	" 25WV 1μF (489D105X0025A1)	
R2054	J24205225	" " "	225J 2.2MΩ				
POTENTIOMETER							
VR2001	J51762471	H0521A105A-470B	470ΩB	C2057	K70127225	" 16WV 2.2μF (CS15E1C2R2M)	
CAPACITORS							
C2114	K10176102	Ceramic	50WV 0.001μF (DD104B102K50)	C2005,2095	K70107335	" 10WV 3.3μF (CS15E1A3R3M)	
C2010	K22170201	Chip	50WV 0.5pF (C2012CH1H0R5CFA)	C2035,2101	K70120002	" 16WV 10μF (489D106X0016C1)	
				C2048,2059	K40179001	Electrolytic 50WV 1μF (ECE-A1HK010)	

C2038,2066,2072,2094	K40129012	" 16WV 10 μ F (ECE-A1CK100)		Q9000280 Q9000281	NC-18B NC-18C	117VAC 220-234VAC
C2063	K40129018	Electrolytic 16WV 47 μ F (ECE-A1CK470)				
C2053,2067	K40089007	" 6.3WV 100 μ F (ECE-A0JK101)		D3000325	Carrying Case*	
		TRIMMER CAPACITOR		D3000344	CSC-6(B) for w/FNB-3 or FBA-5	
TC2001	K91000102	ECR-GA035M30 35pF		D3000351	CSC-7(B) for w/FNB-4 CSC-9(B) for w/FNB-3 or FBA-5 & FTT-3	
		TRANSFORMERS		D3000370	CSC-12(B) for w/FNB-4 & FTT-3	
T2001,2002	L0021418				* optional same models	
		INDUCTORS				
L2001,2002,2004	L1190109	FL3H-R33M 0.33 μ H				
L2003	L0021420					
	L1020680					
	L1190108	FL3H-R68M 0.68 μ H				
	L1190141	FL3H-100K 10 μ H				
	L1190110	FL3H-4R7K 4.7 μ H				
L2008, 2010(A,B,X), 2012, 2014(A,C,X)	L0021420		FTE-2 TONE BURST UNIT (Models B and C)			
			Symbol No.	Part No.	Description	
				F2577000	Printed Circuit Board	
				C025770A C025770B	PCB with Components 1750Hz Tone Model 1800Hz Tone Model	
L2007, 2009(A,B,X), 2011, 2013(A,B,C,X)	L0021434				IC	
			Q5001	G1090239	TC5082P	
		SWITCHES				
S2001	N6090038	SSS313				
S2002	N6090052	SSS323			CRYSTALS	
			X5001	H0101982	HC-18/T	7.168MHz (1750Hz Tone)
		TERMINAL POSTS				
	Q5000016	TP-E	X5001	H0101983	HC-18/T	7.3728MHz (1800Hz Tone)
	R0106700B	Shield case				
	R0106710	Shield cover				
	R0107560B	Shield plate				
					RESISTORS	
			R5003	J00215683	Carbon film	1/8W 68k Ω TJ
			R5002	J01215154	" "	" 150k Ω TJ
			R5001	J00215474	" "	" 470k Ω VJ
ACCESSORIES					CAPACITORS	
Symbol No.	Part No.	Description	C5001	K00175150	Ceramic disc 50WV 15pF	SL (DD104SL150J50V)
	Q3000042	Antenna YHA-44A	C5002,5003	K00175330	" " " 33pF	" (DD104SL330J50V)
		Ni-Cd Battery Pack*	C5006	K12171102	" " " 0.001 μ F	E (DD104E102P50V)
	D3000315	FNB-3	C5005	K14180103	" " 63WV 0.01 μ F	FZ (RD871-1FZ103Z63V)
	D3000316	FNB-4				
		Dry Battery Case*			SIP CONNECTOR	
	D3000317	FBA-5	J5001	P0090373	5703-06CPB	
		Charger for FNB-3*				
	Q9000070	NC-9A 100VAC				
	Q9000071	NC-9B 117VAC				
	Q9000072	NC-9C 220-234VAC	FTS-7 TONE ENCODER/DECODER (D3000321)			
			Symbol No.	Part No.	Description	
				F2578101A	Printed Circuit Board	
		Charger for FNB-4*				
	Q9000279	NC-18A 100VAC				

		IC			RESISTORS
Q1001	G1090577	MN6520	R6002	J24205561	Chip RMC-1/10T 561J 560Ω
			R6003	J24205222	" " " 222J 2.2kΩ
			R6001	J24205103	" " " 103J 10kΩ
		DIODES	R6004,6005	J24205823	" " " 823J 82kΩ
D1001,1002	G2090244	Schottky Barrier 1SS106			
					CAPACITORS
		CRYSTAL	C6001,6002	K22170227	Chip 50WV 47pF CH (C2012CH1H470JFA)
X1001	H0102571	MS-309 4.194304MHz	C6003-6006, 6008,6011	K22170805	" " 0.001μF B (C2012B1H102MFA)
		RESISTORS	C6007	K22170817	" " 0.01μF B (C2012B1H103MFA)
R1009,1010	J24205102	Chip RMC 1/10T 102J 1kΩ	C6008	K22141904	" 25WV 0.1μF D (C3216D1E104MFA)
R1002	J24205222	" " " 222J 2.2kΩ	C6010	K40129012	Electrolytic 16WV 10μF (ECE-A1CK100)
	J24205472	" " " 472J 4.7kΩ			
R1003,1007,1008	J24205103	" " " 103J 10kΩ			
R1004,1005	J24205123	" " " 123J 12kΩ			
R1001	J24205104	" " " 104J 100kΩ			
				N5090020	KEYPAD SM-723
		POTENTIOMETER			
VR1001	J51750473	H0423A047-47KB 47kΩB	MIC1	M3290005	MICROPHONE EM-78C
			SP1	M4090063	SPEAKER CO35A13
		CAPACITOR			
C1008,1009	K22170217	Chip Ceramic 50WV 18pF CH (C2012CH1H180JFA)		R3502640	Panel
C1005	K22171004	" " " 0.01μF F (C2012F1H103ZFA)		R0101820	Trim band
C1002,1004	K22141904	" " 25WV 0.1μF D (C3216D1E104MFA)		R7049012	Speaker net
C1003	K72080002	Chip Tantalum 6.3WV 4.7μF (F950J475MA1)			
C1001,1006	K72080003	" " " 10μF (F950J106MC1)			
C1007	K72060007	" " 4WV 100μF (F950G107MH1)			
		SWITCH			
S1001	N7090030	SGK1072			
		CONNECTOR			
J1001	P0090373	5703-06CPB			
FTT-3 DTMF PANEL UNIT (D3000348)					
Symbol No.	Part No.	Description			
	F2586100	Printed Circuit Board			
Q6001	G1090508	IC	LR4087		
Q6002	G3327120G	TRANSISTOR	2SC2712GR		
D6001	G2090208	LED	PR4632K		
		CERAMIC RESONATOR			
CO6001	H7900120	R3.58M			



